

Axial fans/Jet fans AXC, AXCBF, AXR, AXS, AJR, AJ8

Installation and Operating Instructions

GB

Document in original language | · 008

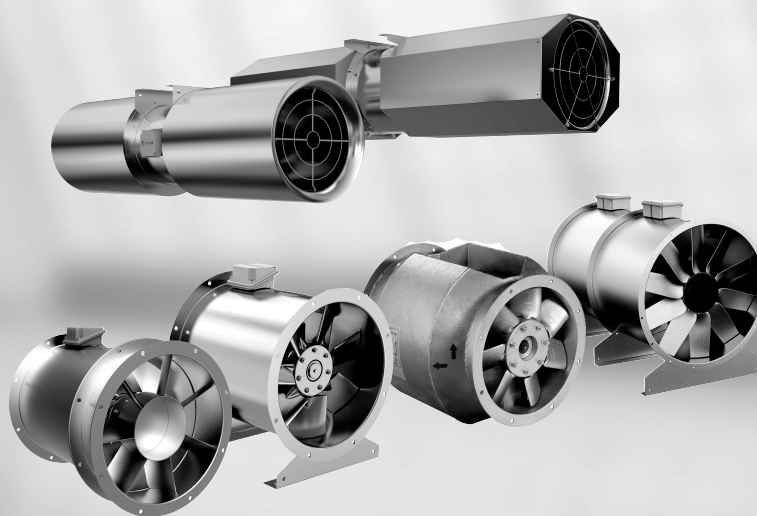

© Copyright Systemair AB
All rights reserved
E&OE

Systemair AB reserves the rights to alter their products without notice.
This also applies to products already ordered, as long as it does not affect the previously agreed specifications.

Contents

1	General information	1	7.3	Installation jet fans	18
1.1	Warning symbols	1	7.3.1	Deflector	19
1.1.1	Instruction symbols	1	8	Electrical connection	19
2	Important safety information	1	8.1	Protecting the motor	19
2.1	Personnel	2	8.2	Connection	20
2.2	Personal protective equipment	2	8.2.1	Terminal box	20
2.3	5 rules of electrical safety	2	8.2.2	Wiring diagram	21
3	Warranty	2	8.3	Frequency converter (if used)	21
4	Delivery, transport, storage	2	9	Commissioning	22
4.1	Delivery	3	9.1	Tests	22
4.2	Transport	3	9.2	Commissioning of speed-controlled fans	22
4.3	Storage	3	9.3	Adjusting the blade angle	22
5	Description	4	10	Operation	22
5.1	General	4	11	Troubleshooting/maintenance/repair	23
5.1.1	Fan and motor data	4	11.1	Troubleshooting	23
5.1.2	Temperature types	4	11.2	Maintenance	24
5.1.3	Air gap between housing and impeller	5	11.3	Variable-speed fans	25
5.2	Description axial fans (AXC, AXR, AXS)	5	11.4	Overhaul/further maintenance	25
5.2.1	Construction	6	11.5	Spare parts	26
5.2.2	Types & variants	6	12	Cleaning	26
5.2.3	Accessories	7	13	Deinstallation/dismantling	26
5.3	Description Jet fans	8	14	Disposal	26
5.3.1	Description AJR/AJ8	8	15	Commissioning Report	27
5.4	Description AXCBF	9			
5.4.1	Construction	10			
5.5	Intended use	11			
6	Name plate and type key	12			
7	Installation	13			
7.1	Vibration dampers	14			
7.2	Installation positions	15			
7.2.1	Installation of the ventilation system	16			
7.2.2	Installation of flexible connections	17			
7.2.3	Installation silencer	18			
7.2.4	(K), (B), (F)– fans – special points	18			
7.2.5	Air gap	18			

1 General information

1.1 Warning symbols



Danger

Direct hazard

Failure to comply with this warning will lead directly to death or to serious injury.



Caution

Hazard with a low risk

Failure to comply with this warning may lead to moderate injuries.



Warning

Potential hazard

Failure to comply with this warning may lead to death or serious injury.

Important

Hazard with risk of damage to objects

Failure to comply with this warning will lead to damage to objects.



Note:

Useful information and instructions

1.1.1 Instruction symbols

Instruction

- ◆ Carry out this action
- ◆ (if applicable, further actions)

Instruction with fixed sequence

1. Carry out this action
2. Carry out this action
3. (if applicable, further actions)

2 Important safety information

Planners, plant builders and operators are responsible for the proper assembly and intended use.

- ◆ Read the operating instructions completely and carefully.
- ◆ Keep the operating instructions and other valid documents, such as the circuit diagram or motor instructions, with the fan. They must always be available at the place of use.
- ◆ Observe and respect local conditions, regulations and laws.
- ◆ Abide by the system-related conditions and requirements of the system manufacturer or plant constructor.
- ◆ Safety elements may not be dismantled, circumvented or deactivated.
- ◆ Only use the fan in operational condition, if in doubt contact Systemair.
- ◆ Provide generally prescribed electrical and mechanical protective devices.
- ◆ During installation, electrical connection, commissioning, troubleshooting, and maintenance, secure the location and premises against unauthorised access.
- ◆ Do not circumvent any safety components or put them out of action.
- ◆ Keep all the warning signs on the fan complete and in a legible condition.
- ◆ The device is not to be used by persons (including children) with reduced physical, sensory or mental capabilities, or lack of experience and knowledge, unless they have been given supervision or instruction.
- ◆ Do not allow children to play with the device.

2.1 Personnel

The fan may only be used by qualified, instructed and trained personnel. The persons must know the relevant safety directives in order to recognise and to avoid risks. The individual activities and qualifications can be found in Table 1 *Qualifications*, page 2.

Table 1 Qualifications

Activities	Qualifications	
Storage, operation, transport, cleaning, disposal	Trained personnel (see following note)	
Electrical connection, commissioning, electrical disconnection	Electrical expert or matching qualification	
Installation, disassembly	Fitter or matching qualification	
Maintenance	Electrical expert or matching qualification	Fitter or matching qualification
Repair	Electrical expert or matching qualification	Fitter or matching qualification
	Smoke extraction fans and EX fans only by agreement with Systemair.	



Note:

The operator is responsible for ensuring that personnel are instructed and have understood the contents of the operating instructions. If something is unclear, please contact Systemair or its representative.

2.2 Personal protective equipment

◆ Wear protective equipment during all work in the vicinity of the fan.

- protective working clothes
- protective working gloves
- goggles
- protective working shoes
- helmet
- hearing protection

2.3 5 rules of electrical safety

1. Disconnect (disconnection of the electrical system from live components at all terminals)
2. Prevent reactivation
3. Test absence of voltage
4. Ground and short-circuit
5. Cover or restrict adjacent live parts

3 Warranty

For the assertion of warranty claims, the products must be correctly connected and operated, and used in accordance with the data sheets. Further prerequisites are a completed maintenance plan with no gaps and a commissioning report. Systemair will require these in the case of a warranty claim. The commissioning report is a component of this document. The maintenance plan must be created by the operator, see section 11.2 *Maintenance*.

4 Delivery, transport, storage

Safety information

Warning: Risk from rotating fan blades

◆ Prevent access by unauthorised persons by safety personnel or access protection.

Warning: Suspended loads

- ◆ Wear protective equipment during all work in the vicinity of the fan, details see 2.2 *Personal protective equipment*, page 2.
- ◆ Do not walk under suspended loads.
- ◆ Make sure that there is nobody under a suspended load.

4.1 Delivery

Each fan leaves our plant in an electrically and mechanically proper condition. We recommend transporting the fan to the installation site in the original packaging.

Checking delivery

- ◆ Check the packaging and the fan for transport damage. Any findings should be noted on the cargo manifest.
- ◆ Check completeness of the delivery.

Unpacking



Warning

When opening the transport packaging, there is a risk of damage from sharp edges, nails, staples, splinters etc.

- ◆ Unpack the fan carefully.
- ◆ Check the fan for obvious transport damage.
- ◆ Only remove the packaging shortly before assembly.
- ◆ Wear protective equipment during all work in the vicinity of the fan, details see 2.2 *Personal protective equipment*, page 2.

4.2 Transport

Safety information

Warning: Electrical or mechanical hazards due to fire, moisture, short circuit or malfunction.

- ◆ Never transport the fan by the connecting wire, terminal box, impeller, protection grille, inlet cone or silencer.
- ◆ In open transport, please make sure that no water can penetrate into the motor or other sensitive parts.
- ◆ We recommend transporting the fan to the installation site in the original packaging.

Caution: If transported without care during loading and unloading, the fan may be damaged.

- ◆ Load and unload the fan carefully.
- ◆ Use hoisting equipment that is suitable for the weight to be hoisted.
- ◆ Observe the transportation arrows on the packaging.
- ◆ Use the fan packaging exclusively as transport protection and not as a lifting aid.

4.3 Storage

Safety information

Warning: Risk of injury and damage to the fan.

- ◆ Do not stack the fans on top of one another.
- ◆ Do not use transport packaging as hoisting aids.
- ◆ Use hoisting equipment that is suitable for the weight to be hoisted.

Storage more than 3 months

- ◆ Turn the impeller at least 10 revolutions once a month.
- ◆ Please ensure that the impeller is at a different position afterwards.

Preconditions

- ◆ Store the devices in a clean, dry and vibration-free environment.
- ◆ Storage temperature should be between -20°C and 60°C.

Storage more than 12 months

- ◆ We recommend an inspection by the after-sales service of Systemair before commissioning.

5 Description

5.1 General

- The fan conveys air in an axial direction from the intake side via the electric motor to the outlet side. (except AXCBF).
- The electrical connection is made through a terminal box installed on the outside of the housing (except AXCBF).

Sensors (optional)

Sensors can be connected to the fan to monitor the roller bearings and for vibration monitoring.

Standstill heating (optional)

The standstill heating starts when the motor switches off and vice versa.

5.1.1 Fan and motor data

- The technical data of the fan can be seen on the name plate or the data sheet.
- The motor data can be found on the name plate of the motor or in the technical documents of the motor manufacturer.
- The data on the name plate of the fan apply to "standard air" according to ISO 5801.

5.1.2 Temperature types

Table 2 Types of fans

Type	Diameter [mm]	Long-term operation -20°C...55°C	Long-term operation -20°C...200°C	(B) 300°C/ 120 min.	(F) 400°C/ 120 min.
AXC ¹ /AXR/AXS	315 – 1600	X			
AXCBF	250– 800	X	X		
AXC (B) ¹ /AXR (B)	315 – 1600	X		X	
AXC (F) ¹ /AXR (F)	315 – 1600	X			X
AJR/AJ8	315 – 400	X			
AJR (B)/AJ8 (B)	315 – 400	X		X	
AJR (F)/AJ8 (F)	315 – 400	X			X

¹ also –P, –PV and –G

5.1.3 Air gap between housing and impeller

			AXC AXR AXC-P AJR AJ8		AXC (K) AXC (B) AXR (K) AXR (B) AJR (K) AJR (B) AJ8 (K) AJ8 (B)		AXC (K)-P AXC (B)-P AXC (K)-PV AXC (B)-PV		AXC (F) AXR (F) AJR (F) AJ8 (F)		AXC (F)-P AXC (F)-PV	
			Standard temperature									
Size	Poles	Housing tolerance	Air gap		Air gap		Air gap		Air gap		Air gap	
			min	max	min	max	min	max	min	max	min	max
315	2-pol	1	1	3	2	3,5	2	4	4	6	-	-
355	2-pol	1	1	3	2	3,5	2	4	4	6	-	-
400	2-pol	1	1	3	2	3,5	2	4	4,5	6	-	-
450	2-pol	1	1	3	3	4,5	2,5	4,5	6	6,5	3	5
500	2-pol	1	1	3	3	4,5	2,5	4,5	5	7	3	5
560	2-pol	1	1	3	4	5,5	2,5	4,5	6	8	3,5	5,5
630	2-pol	1	1	3	4	5,5	2,5	4,5	7	9	3,5	5,5
710	4-pol	1	1	3	4	5,5	2,5	4,5	7	9	3,5	5,5
	2-pol						4	6			-	-
800	4-pol	1	1	3	5	6,5	3,5	5,5	8	10	4	6
	2-pol						5	7			-	-
900	4-pol	1	1	3	5	6,5	3,5	5,5	9	11	4	6
1000	4-pol	2	2	5	5	7	4	7	10	12	5	8
1120	4-pol	2	2	5	6,5	8,5	4	7	11,5	14		
1250	4-pol	2		5	7	9	4,5	7,5	12,5	15		
1400	4-pol	2	6	9	7,5	9,5			14	16		
1600	4-pol	3	7	10	8	11,5			16	18		
1800	4-pol	4	10	14	11,5	15,5			18	21		
2000	4-pol	4	10	14	11,5	15,5			20	23		
2240	4-pol	5	12	16	13	18,5			0	0		

5.2 Description axial fans (AXC, AXR, AXS)

- For B3 conventional motors, the motor bracket is made from galvanized steel sheet. B30 “pad mounted” motors are fitted in the housing via threaded rods or a welded motor support.
- The motor with impeller is mounted to a sturdy supporting structure.

5.2.1 Construction

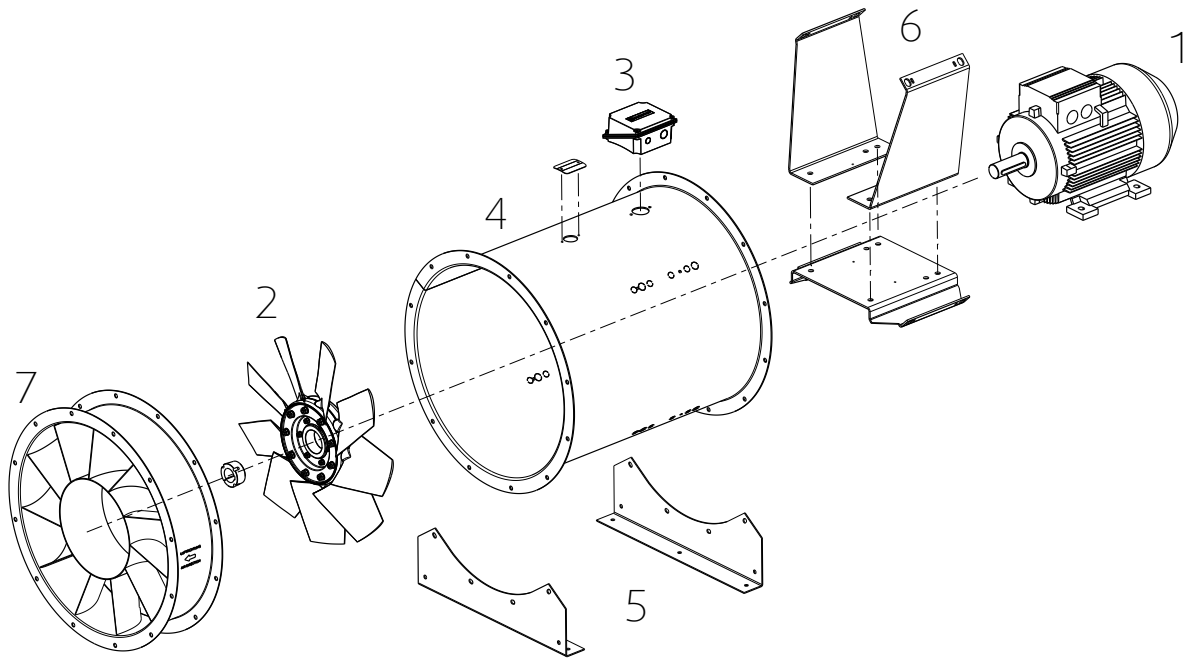

- | | | | | | |
|---|----------|---|--------------|---|--------------------------------|
| 1 | Motor | 3 | Terminal box | 5 | Mounting feet |
| 2 | Impeller | 4 | Housing | 6 | Motor brackets |
| | | 7 | Guide vane | | only available for -PV version |

5.2.2 Types & variants

Table 3 Axial fan base types

Type	Description
AXC	Standard fan of the AXC-series. As a default, the fans are provided in protection class IP55, ISO F.
AXS	Special fans for marine, oil and gas applications.
AXR	The conveying direction can be reversed by switching the direction of rotation.

Table 4 Axial fan variants

Type	Description
-P	Fan of AXC-series which uses impeller design of the "-P" generation.
-PV	Fan of AXC-series which uses impeller design of the "-P" generation and includes bolt on guide vane.
-Box	Fan of AXC-series inside a sound-insulated box.
-G	Fans constructed as garage version. Arrangement of two fans in series, switched behind one another.
(B)	Smoke extract fan suitable for 2 hours at 300°C. As a default, the fans are provided in protection class IP54/55, ISO H. The connection wire from the motor to the terminal box is protected via an additional flexible metal hose. The standard motors (400 V type B3) are without motor protection.
(F)	Smoke extract fan suitable for 2 hours at 400°C. As a default, the fans are provided in protection class IP54/55, ISO H. The connection wire from the motor to the terminal box is protected via an additional flexible metal hose. The standard motors (400 V type B3) are without motor protection.
-SC	Short Casing.

5.2.3 Accessories

Horizontal installation

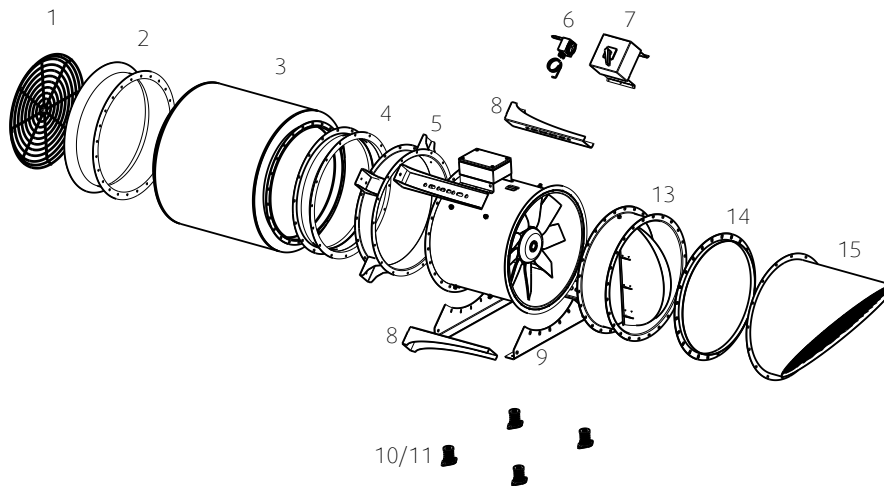

Vertical Installation

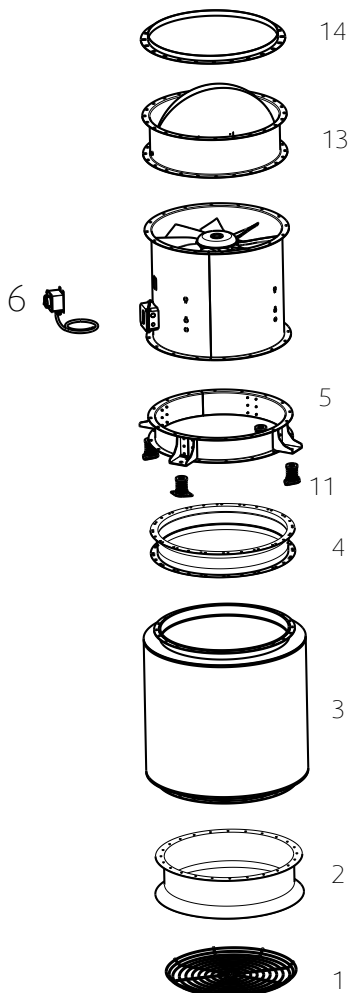

1	SG/SG-20*	Protection guard
2	ESD-F	Inlet cone
3	RSA	Silencer
4	EV, EVH (F400)	Flexible connection
5	MPR	Mounting ring from size 315 to 1000
6	REV (60°C)	Isolator switch
7	REV (fire rated)	Isolator switch
8	MP	Mounting bracket from size 1120
9	MFA	Mounting foot
10	SD	Rubber anti-vibration mounts
11	FSD	Spring anti-vibration mounts
12	ZSD/HNG	Suspension spring anti-vibration mounts/Rubber-metal damper for mounting on the ceiling
13	LRK	Air operated damper
14	GFL	Counter flange
15	ABS	Outlet cowl



Note:

- Some accessories are also available for jet fans and AXCBF, please check our online catalogue or contact Systemair.
- *The distance between safeguard SG-20 and the impeller must be ≥ 850 mm according to ISO 13857.

5.3 Description Jet fans

5.3.1 Description AJR/AJ8

- In B3 conventional motors, the motor bracket is made from galvanized steel sheet. B30 “pad mounted” motors are fitted in the housing via threaded rods or a welded motor support.
- The fan conveys air in an axial direction from the intake side via the electric motor to the outlet side.
- The silencers are equipped with protection grille made of galvanized steel.
- The acoustic insulation is non-flammable in accordance with DIN 4102 as described in directive 97/69 EC.

Table 5 Constructive features

AJR/AJ8	As a default, the fans are provided in protection class IP55, ISO F.
AJR (K)/AJ8 (K)/AJR (B)/AJ8 (B)/AJR (F)/AJ8 (F)	As a default, the fans are provided in protection class IP54/55, ISO H. The wiring from the motor to the terminal box is protected via an additional flexible metal hose. The standard motors (400 V type B3) are without motor protection.

5.3.1.1 Construction

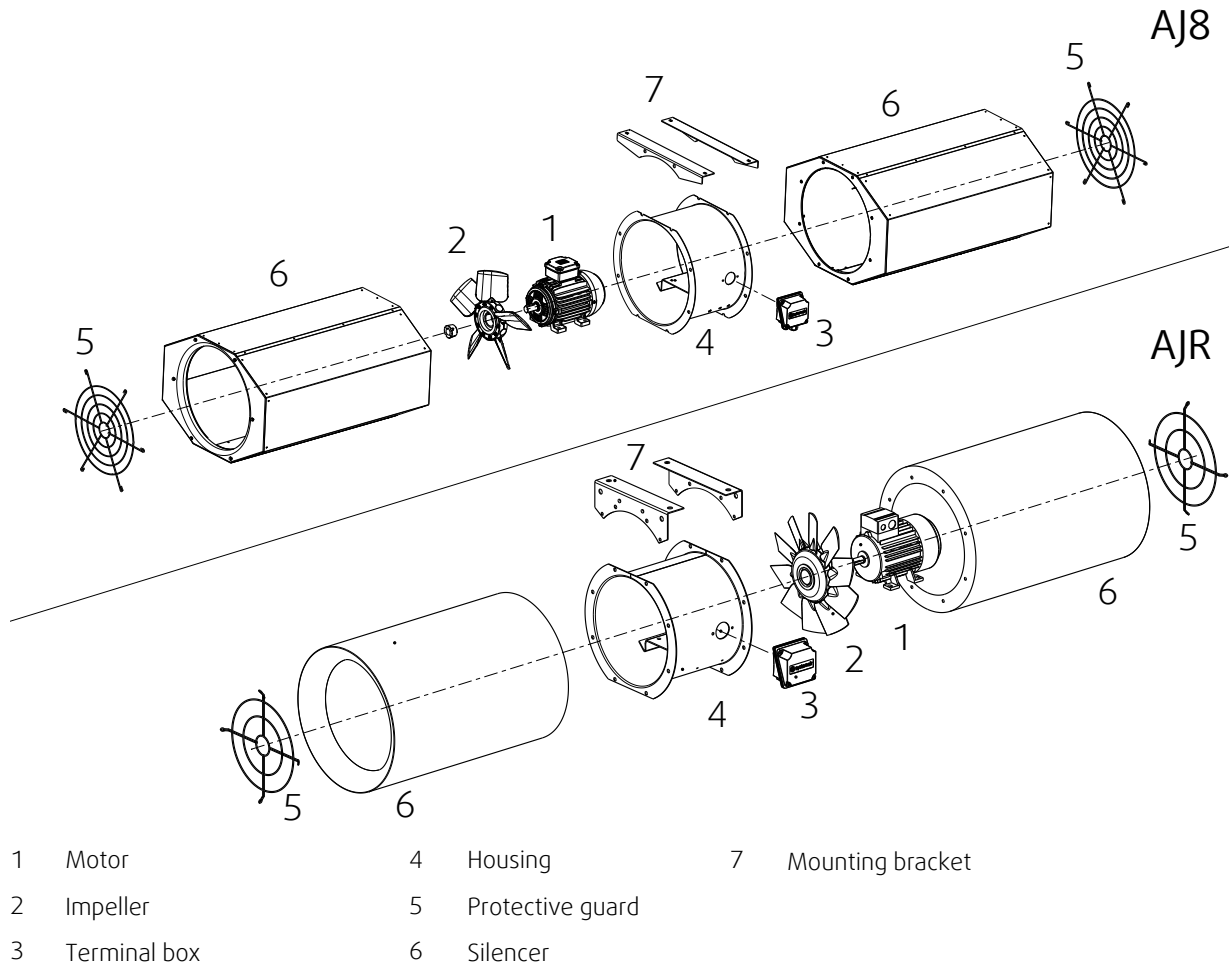
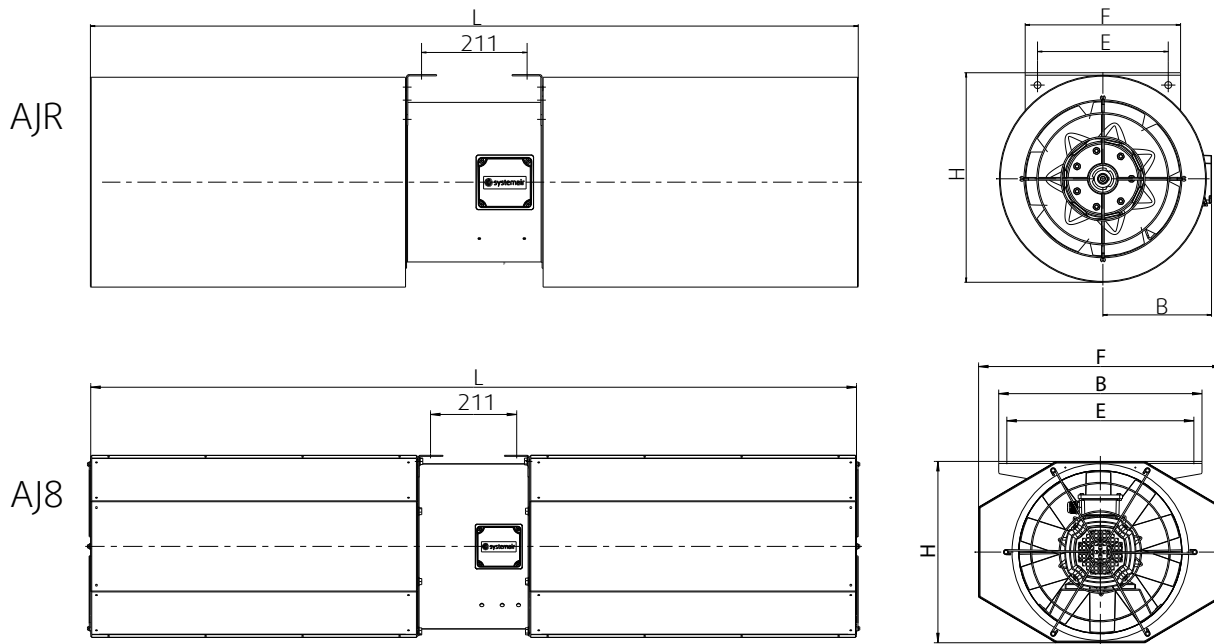

Table 6 Dimensions AJ8, AJR

Size	H [mm]	B [mm]	E [mm]	F [mm]	L [mm]
AJ8 315 (B), (F)	365	375	325	678	1535
AJ8 355 (B), (F)	395	400	355	678	1695
AJ8 400 (B), (F)	445	500	460	727	1875
ARJ 315 (B), (F)	365	223	265	433	1535
ARJ 355 (B), (F)	465	243	305	473	1695
ARJ 400 (B), (F)	505	266	350	516	1875

5.4 Description AXCBF

Directly powered axial fan with motor outside the air flow. The fan can be run in permanent operation up to a conveying media temperature of 200°C. Maximum ambient temperature 55°C. Housing flanges on both sides with bores according to eurovent 1/2 standard. B3 conventional motors with add-on terminal box.

5.4.1 Construction

- 1 Motor
- 2 Impeller
- 3 Housing
- 4 Motor bracket

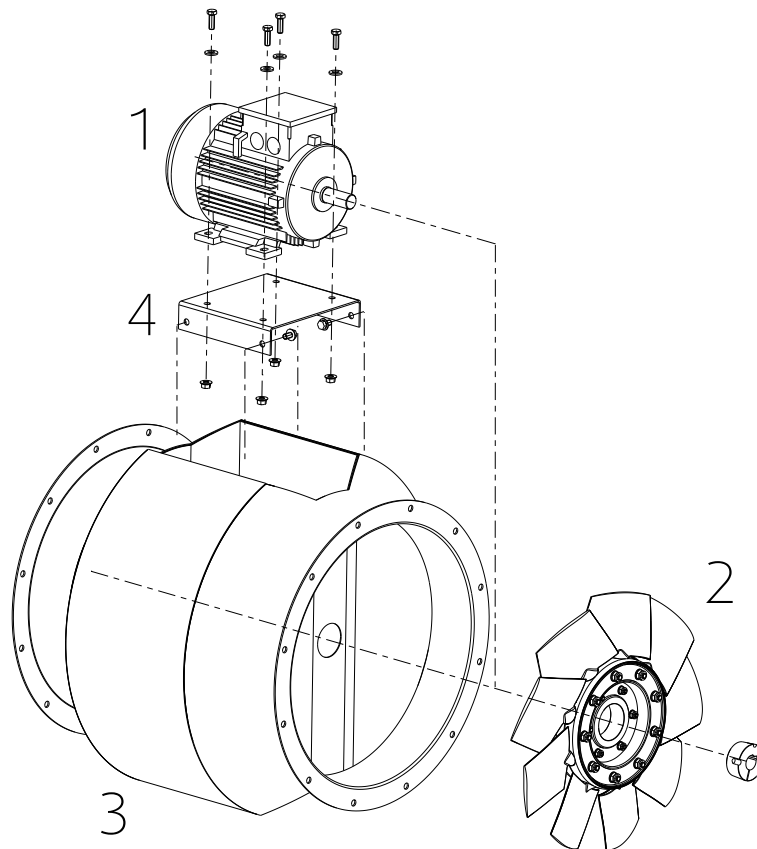
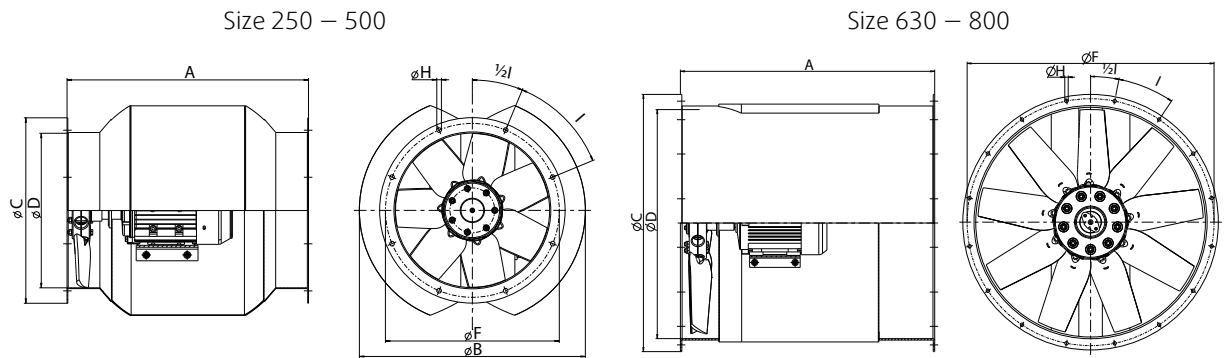

Table 7 Dimensions



Size [mm]	A	Ø B	Ø C	Ø D	Ø F	Ø H	I
AXCBF 250	535	448	328	250	280	10	4x90°
AXCBF 315	535	452	385	320	355	10	8x45°
AXCBF 400	625	585	480	401	450	10	8x45°
AXCBF 500	660	695	590	504	560	12	12x30°
AXCBF 630	790	728	634	-	690	12	12x30°
AXCBF 800	880	890	797	-	860	12	16x22.5°

5.5 Intended use

All axial fans

- The temperature of the air transported through the fan must not exceed the temperature range stated on the name plate.
- For the temperature resistance of the smoke extraction fans (K), (B), (F), which can also be used to extract CO, please refer to the name plate (e.g. 300°C/120 min).

Jet fans

- AJ8 and AJR jet fans are intended for installation in underground and above-ground parking structures, to facilitate ventilation and smoke extraction (K), (B), (F).
- For optimum operation, the jet fan must be suspended horizontally from the ceiling in such a position that intake and outlet are unobstructed.

Axial fans

- The axial fans of the series AXC/AXR/AXCBF in the versions G (K), (B), (F) are intended for installation in ventilation systems.
- The axial fans of the series AXC/AXR/AXCBF are ready-to-use products and are used as components for ventilation devices, machines and systems. These fans can be used to extract, draw in or convey air.
- The fans can be installed both in duct systems and also with free suction via an inlet cone and a suction-side contact protection grille. Free discharge via a contact protection grille is also possible.

Incorrect use

Incorrect use refers mainly to using the fan in another way to that described. The following examples are incorrect and hazardous:

- The fan is not suitable for intake of aggressive media or media with a dust content so high that dust deposits on the impeller or fan housing can affect the operation of the fan.
- The fan must not be installed in hazardous areas (areas with a potentially explosive atmosphere).
- The motors cannot be voltage controlled.

6 Name plate and type key

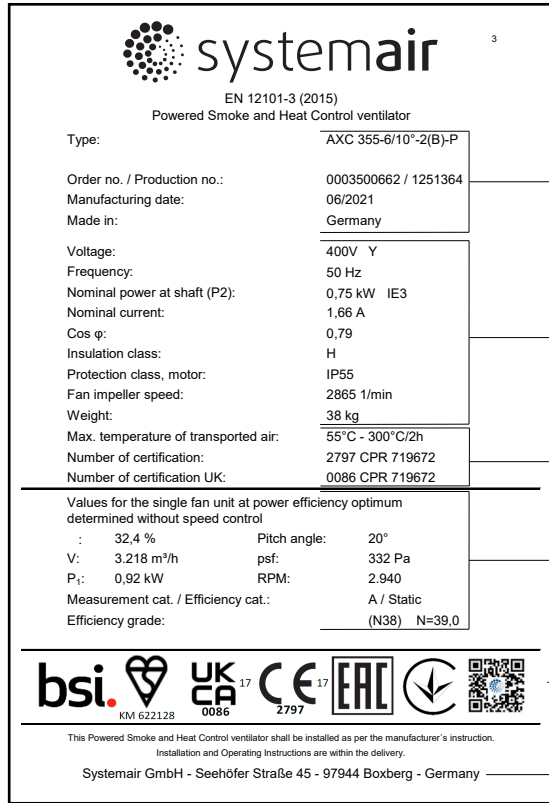

- 1 General data
- 2 Technical data
- 3 Temp./Time information/
only listed on smoke
extraction fans
- 4 ErP data
- 5 Certifications and QR–
Codes
- 6 Manufacturer Address

Table 8 Type key

AXC	355	-6	/10°	-2	(-)(K), (B), (F)	P	-	
								<ul style="list-style-type: none"> • C – counter-rotating • V – guide vane
								<ul style="list-style-type: none"> • G – Garage • A – Low pressure impeller • P – plus (new impeller generation)
								Temperature- Time information (smoke extraction fan), see 5.1.2 <i>Temperature types</i> , page 4
								Number of poles
								Blade angle
								Number of blades
								Nominal diameter of the fan
								AXC Axial fan AXR Axial fan – reversible AXS Axial fan – ship AJR Circular jet fan AJ8 Octagonal jet fan AXCBF Axial fan bifurcated AXC-SC Axial fan-Short Case

7 Installation

Safety information

Danger: Risk that the fan does not work in case of fire.

- ◆ Use installation material with fire resistance classes that meet temperature requirements.

Warning: Danger from falling fan or fan parts.

- ◆ Check the surface before installation for load bearing capacity.
- ◆ Consider all static and dynamic loads when selecting hoisting equipment and fastening components.

General safety information

- ◆ Installation may only be carried out by adequately qualified persons, details see Table 1 *Qualifications*, page 2.
- ◆ Move the impeller of the fan by hand before you install it in order to check whether that moves freely.
- ◆ Prevent the possibility of foreign bodies being drawn in.
- ◆ To reduce transmission of vibration to the duct system, we recommend flexible connections from our accessory range, see 5.2.3 *Accessories*, page 7.
- ◆ Bear in mind that parts of the impeller may protrude out of the fan housing.
- ◆ If the product is installed with free suction or free discharge, install a protection grille to prevent injury from the fan impeller. Make sure that the safety distance agrees with the standards DIN EN ISO 13857 and DIN 24167-1.
- ◆ Tightening torques of screw-type connections according to DIN 13.

Preconditions

- ◆ Ensure that the fan and all its components are undamaged.
- ◆ Ensure that there is enough space to install the fan.
- ◆ Protect against dust and moisture when installing.
- ◆ Do not install the fan if the gap in the table (5.1.3 *Air gap between housing and impeller*, page 5) is not complied with.
- ◆ Ensure that the information on the name plates (fan and motor) matches up with the operating conditions.
- ◆ A warning sign must be attached close to the air outlet, stating that the air outlet must not be covered.
- ◆ Fit the fans in such a way that there is sufficient access for troubleshooting, maintenance and repair.

Tests after long storage time (more than 12 months)



Note:

We recommend an inspection by the after-sales service of Systemair before commissioning.

Test the motor windings:

- ◆ Measure the insulation resistance of each motor winding against grounding at 500 V DC. The insulation resistance must be > 10 mΩ.

Measures for an insulation resistance < 10 mΩ:

1. If the motor has drain plugs, remove them to allow any moisture to drain and replace them when the motor windings are suitably dry.
2. Dry the motor in a warm dry airflow (typically 40 degrees Celsius).
3. Measure the insulation resistance of each motor winding against grounding at 500 V DC.
4. Repeat the aforementioned steps until the measurement outcome > 10 mΩ.

Mounting feet

Depending on the kind of fan and the construction size, mounting feet are either included in the delivery or available as accessories. If you are not sure, check the online catalogue or contact Systemair.

Avoid resonance frequencies**Important****Risk of damage to the fan due to resonance frequencies**

- ◆ The minimum fan speed should be double the resonance frequency of the anti-vibration system (vibration dampers).
- ◆ To avoid resonance frequencies, see 8.3 *Frequency converter (if used)*, page 21.

7.1 Vibration dampers**Important****Risk of damage to the fan due to incorrect vibration dampers**

- ◆ Use the vibration dampers suitable for the respective weight.
- ◆ Use the vibration dampers with fire resistance classes that match the respective application.

Sylodyn vibration kit (if used)

The responsibility for the Sylodyn vibration kit installation is with the buyer/installer.

Important**Risk of damage to the fan due to incorrect installed vibration dampers**

- ◆ The fan shall rest entirely on the sylodyn anti vibration blocks. It is important that the fan is not pressed against the mounting frame, therefore the minimum distance of 15 mm has to be kept, see following picture.

1	Hexagonal head set screw	
2	Sylodyn anti vibration block	Available as Systemair accessory with a hole \varnothing 16mm
3	Safety plate	Available as Systemair accessory with a hole \varnothing 16mm
4	Hexagonal nut	
5	Mounting foot	
6	Mounting frame	

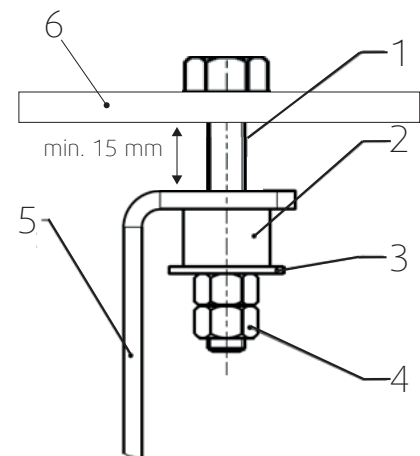

Lifting and positioning

The weight of the fan units varies depending on the motor size and accessories. As a result, the fan unit can also be very bulky and heavy. You can find precise information on the name plate or the data sheet.



Caution
Risk of parts falling down
 ♦ When fitting the fan, pay attention to its weight and the weight of the components.

Lifting

- ♦ Lift the fan unit slowly and carefully.
- ♦ Use hoisting gear permitted for the weight of the fan.
- ♦ Attach the hoisting equipment to flanges and foot bores or at the marked places.
- ♦ Use transport equipment (e.g. lifting eyes) if available.
- ♦ Please observe the marking "oben/top" on the fan.

Positioning

- ♦ Observe the arrows on the name plate or the housing of the fan. They show the direction of rotation and air flow.
- ♦ Position the fan unit so that it is standing in the planned direction of flow.
- ♦ Provide enough free space for inspection and maintenance work on the fan unit.

Anchor

- ♦ Use suitable fittings.
- ♦ If you are not sure, contact Systemair.

7.2 Installation positions

AXC, AXR, AXS

- ♦ Consider below guideline for installation positions.



Note:

- Order process (Systemair configurator): If the type of installation is e.g. "SO" (vertical installation, >= IEC 160), a suitable motor is automatically used (in this case with different bearings).
- Please contact Systemair if a position marked with a "red-cross" is required for an existing fan.

Fans equipped with

- B3 <160 and B30 (Pad)

The installation is possible in any mounting position.

B3 >160

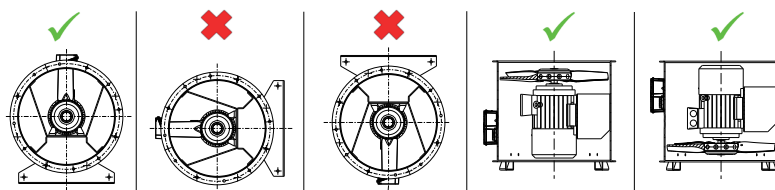

AXCBF

Important
Overheating motor
 ♦ The motor opening must be faced upwards to avoid trapped heat.

7.2.1 Installation of the ventilation system

Preconditions

- ◆ The air flow of the fan must be able to open the air operated damper (LRK).

Installation duct

- ◆ Do not place a duct bend directly before or after the fan!
 - This can cause damage to the bearings or other parts of the fan.
 - The duty point may not be reachable.
 - The fan may make noise.
- ◆ Ensure a direct, smooth and constant air flow to the device. Ensure a free exhaust, see the following pictures.
- ◆ Install an inlet cone or a channel section with a length of at least $2.5 \times D$. It is not recommended to install the protective guard directly in front of the impeller (without inlet cone), as additional noise and a deterioration of the air performance may result.
- ◆ To reduce transmission of vibration to the duct system, we recommend flexible connections from our accessory range, see 5.2.3 *Accessories*, page 7.

D = nominal diameter

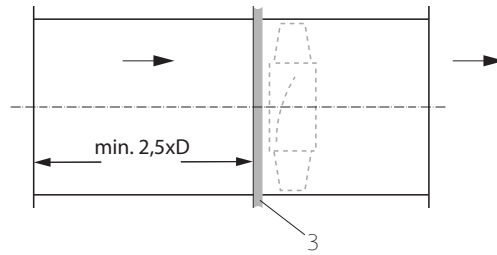
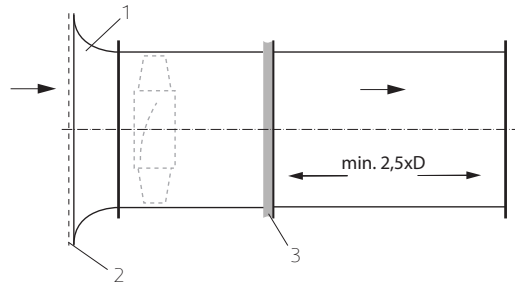

1 Inlet cone 2 Protective guard 3 Flexible connection

Distance from the wall/ceiling

- ◆ Ensure enough distance between the ceiling and the wall.
 - The duty point may not be reachable.
 - The fan may make noise.

If the minimal distances are not possible for construction reasons, install a deflector in front of the fan in a way that ensures a direct, smooth and constant flow of air. Contact with rotating parts must be ruled out at all times – either by ducts of a corresponding length or by protective grids.

D = Nominal diameter

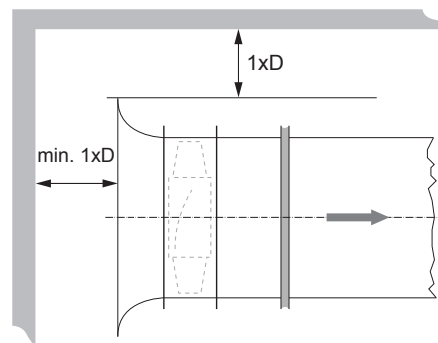

7.2.2 Installation of flexible connections

Important

Increasing noise emission

- ◆ Do not install the flexible connections at an angle.



Note:

When fitting the flexible connections, make sure that they are fitted according to the installation length (Table 9 *Flexible connections – Installation length*, page 17), without compression or tensile strain. They must not be used to compensate any lack of precision in the assembly.

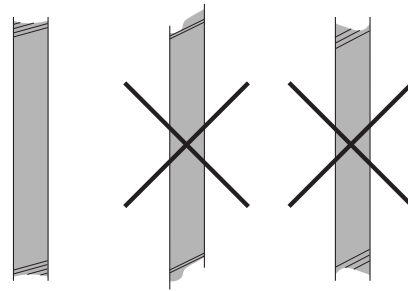
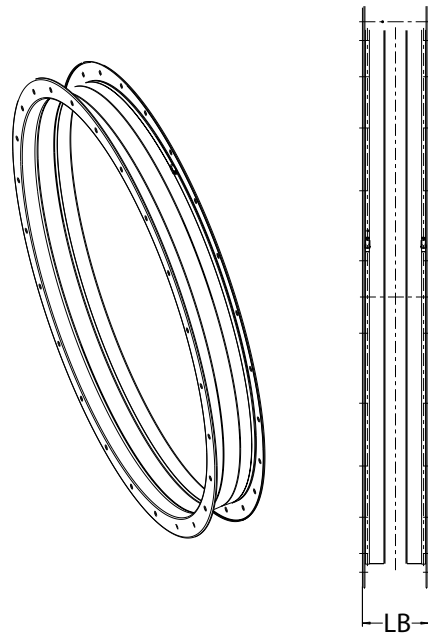

Table 9 Flexible connections – Installation length

Size	EV (-25...70°C)		EVH (400°C/2h)	
	LB full length [mm]	LE Installation length [mm]	LB Overall length [mm]	LE Installation length [mm]
315	157 (+/-5)	LB – 10	147 (+/-5)	LB – 10
355	157 (+/-5)	LB – 10	147 (+/-5)	LB – 10
400	157 (+/-5)	LB – 10	147 (+/-5)	LB – 10
450	157 (+/-5)	LB – 10	147 (+/-5)	LB – 10
500	157 (+/-5)	LB – 10	147 (+/-5)	LB – 10
560	157 (+/-5)	LB – 10	147 (+/-5)	LB – 10
630	157 (+/-5)	LB – 10	147 (+/-5)	LB – 10
710	157 (+/-5)	LB – 10	147 (+/-5)	LB – 10
800	157 (+/-5)	LB – 10	147 (+/-5)	LB – 10
900	157 (+/-5)	LB – 10	147 (+/-5)	LB – 10
1000	157 (+/-5)	LB – 10	147 (+/-5)	LB – 10
1120	157 (+/-5)	LB – 15	147 (+/-5)	LB – 15
1250	157 (+/-5)	LB – 15	147 (+/-5)	LB – 15
1400	157 (+/-5)	LB – 15	200 (+/-5)	LB – 15
1600	157 (+/-5)	LB – 15	200 (+/-5)	LB – 15



7.2.3 Installation silencer

- ◆ Ensure correct installation of the silencer.
 - This can cause damage to the bearings or other parts of the fan.
 - The duty point may not be reachable.
 - The fan may make noise.
- ◆ Ensure a direct, smooth and constant air flow to the device. Ensure a free exhaust, see the following pictures.
- ◆ To reduce transmission of vibration to the duct system, we recommend flexible connections from our accessory range, see 5.2.3 *Accessories*, page 7.

1	Plenum box with perforated sheet (flow straightener)	not available as Systemair accessory	
2	Deflector with inner core	not available as Systemair accessory	
3	Baffles	not available as Systemair accessory	
4	Flexible connection	available as Systemair accessory	
5	Flexible connection	available as Systemair accessory	
6	Inlet cone	available as Systemair accessory	

7.2.4 (K), (B), (F) – fans – special points

Type	Special points for assembly
AXC (B), (K), (F)	Smoke exhaust fans are suitable for installation inside or outside a smoke reservoir, as well as outdoors. If positioned outside the smoke reservoir, the fan must be provided with heat insulation by the customer. The heat insulation must be provided with fire proof material L120 according to DIN 4102-4.
AXR (B), (K), (F)	
AXC-P (B), (F)	
AXC-PV (B), (F)	

7.2.5 Air gap

Ensure that the air gap between the housing and the impeller is complied with.

- ◆ Contact Systemair
- ◆ Do not install the fan if the gap in the table is not complied with.
- ◆ Check if the air gap complies with the table.5.1.3 *Air gap between housing and impeller*, page 5

7.3 Installation jet fans

Always install in a horizontal position.

7.3.1 Deflector

For optimal guidance of the air current, a deflector made of galvanized steel sheet can be mounted on the pressure-side silencer (accessory).

The deflector as accessory for AJR/AJ8 is delivered in a separate package.

- ◆ Before installing the jet fan, fasten the deflector on the silencer of the pressure side (see arrow).
- ◆ Position the deflector fins so that after fastening the jet fan to the ceiling, the air flow is directed downwards at a 10° angle. It may be possible to readjust the fans afterwards depending on the structures located in the immediate vicinity, such as girders.

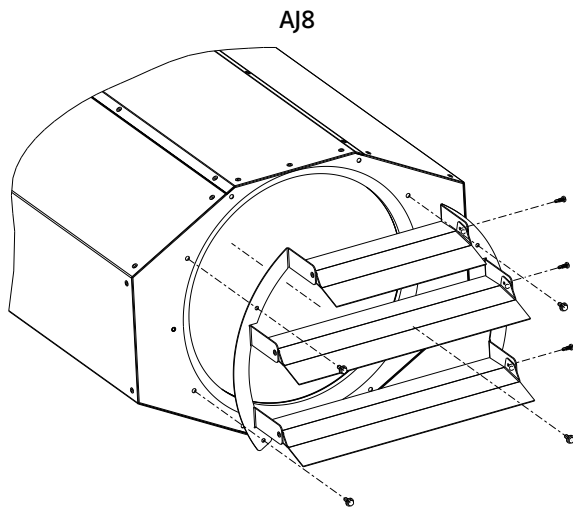

Position the fins to the specified angle and secure them with 4.2 x 13 self-drilling screws. Use M4 x 12 self-locking screws to fasten the deflector to the fan.

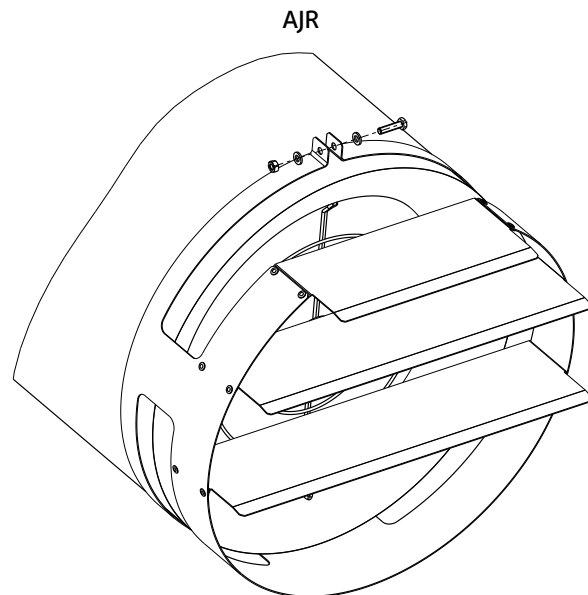

Fasten the deflector with an M6 x 40 screw, an M6 nut and a Ø6 serrated washer.

8 Electrical connection

Safety information

Warning: Danger from electrical voltage.

- ◆ Observe the 5 rules of electrical safety, see 2.3 *5 rules of electrical safety*, page 2.
- ◆ Prevent the ingress of water into the connection box.
- ◆ Electrical connection may only be carried out by adequately qualified persons, details see Table 1 *Qualifications*, page 2.

8.1 Protecting the motor

Important

Damage to motor due to overcurrent, overload or short circuit.

- ◆ Lead-out temperature monitors must be integrated in the control circuit in such a way that, if a fault occurs, the motor cannot switch on again automatically after it has cooled down.
- ◆ Motor lines and temperature monitor lines should be laid separately on principle.
- ◆ Without thermal protection: Use a motor protection switch!

Important

Damage to motor due to over temperature.

- ◆ To avoid too many starts and stops a falling delay time of minimum 5 minutes has to be realized in the control circuit.

Table 10 Motor protection

Type	Motor protection	Thermal protection, standard	Speed regulation
Fans for long-term operation –20 °C...55 °C only, see 5.1.2 <i>Temperature types</i> , page 4	By customer	PTC	Possible via frequency converter
AXC (B),(F),(K) AXR (B),(F),(K) AXC (B)-P, (F)-P AXC (B)-PV, (F)-PV AJ8 (B), (K), (F) AJR (B), (K), (F)	By customer- must be bypassed in case of fire	without (PTC optional)	Possible via frequency converter

8.2 Connection

- ◆ Check that the data on the name plate matches the connection data.
- ◆ Complete the electrical connection according to the circuit diagram.
- ◆ Use all of the locking screws.
- ◆ Insert the screws by hand to avoid damaging the thread.
- ◆ Tighten all glands well in order to guarantee protection class IP.
- ◆ Screw the lid of the terminal box/inspection switch evenly tight.
- ◆ Connect the cable end in a dry environment!
- ◆ Install a circuit breaker in the permanent electrical installation, with a contact opening of at least 3 mm at each pole.

Protective grounding wire

The protective grounding must have a cross-section equal to or greater than that of the phase conductor.

Residual current circuit breaker

All-current-sensitive residual current circuit breakers are required for use in alternating-current systems with 50/60 Hz, in combination with electronic devices such as EC motors, frequency converters or uninterruptible power supplies (UPS).

Type	Electrical Connection
AXC, AXR, AXS, AXC-P, AXC-PV, AJR, AJ8	Connection via terminal box. The terminal box is fitted on the outside of the housing.
AXCBF	Connection via terminal box. The terminal box is attached to the motor.

8.2.1 Terminal box

The below terminal boxes are used for fans up to a nominal current of 100 A. If the nominal current exceeds 100 A other terminal boxes are used.

- up to size* 900
- up to 63 A

A: M16x1,5
B: M25x1,5

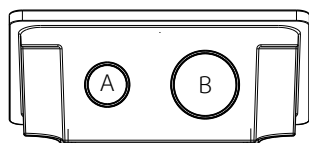

- from size* 1000
- up to 100 A

A: M16x1,5
B: M40x1,5
C: M50x1,5

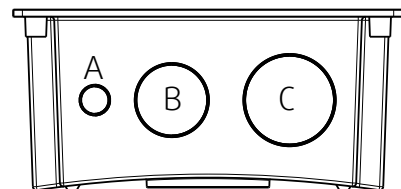

*nominal diameter of the fan

8.2.2 Wiring diagram

Important

Wrong connection can damage or destroy the motor.

- ◆ Use the information on the nameplate to select the correct connection diagram.

Star / Delta

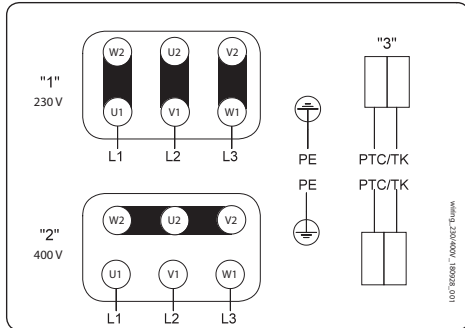

- "1" – Δ
- "2" – Y
- "3" – Thermal motor protection optional

Star / Delta

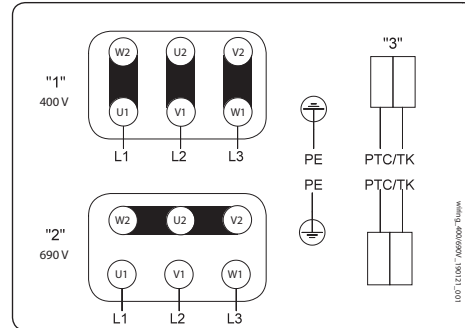

- "1" – Δ
- "2" – Y
- "3" – Thermal motor protection optional

Two sepeare windings

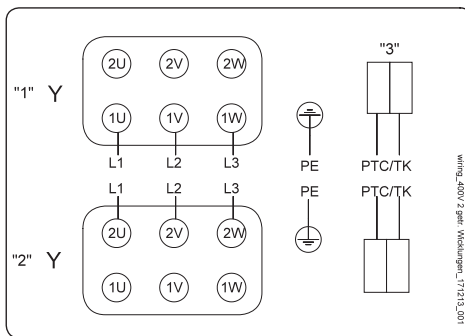

- "1" – Connection for low speed
- "2" – Connection for high speed
- "3" – Thermal motor protection optional

Dahlander

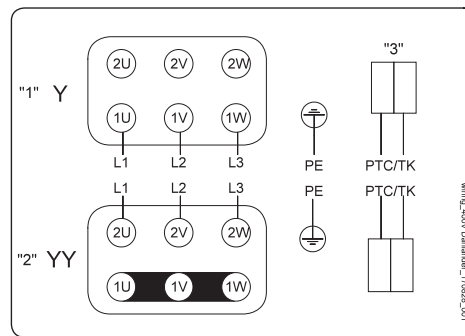

- "1" – Connection for low speed
- "2" – Connection for high speed
- "3" – Thermal motor protection optional

8.3 Frequency converter (if used)

Risk from resonant frequencies when using frequency converter.

- ◆ Only operate the fan outside these speed ranges.
- ◆ Pass through these speed ranges so quickly that any vibration cannot exceed the admissible resonant frequency values.
- ◆ For variable-speed fans, use a permanent vibration monitoring for long-term safe operation.
- ◆ Observe the operating instructions of the frequency converter.

Operation of the frequency converter

- ◆ Heating of the motor due to use of a variable frequency drive must be checked in the application by the customer.
- ◆ Avoid running the fan via the frequency converter below 10 Hz.
- ◆ Starting time: min. 60 sec.

Commissioning of the frequency converter

- ◆ Install the fan and frequency converter as near as possible to one another.
- ◆ Use shielded cables.
- ◆ All components (fan, frequency converter and motor) must be grounded.
- ◆ We recommend using all-pole sinus filters.
- ◆ Never exceed the maximum impeller rotation speed indicated on the name plate of the fan.

9 Commissioning

Warranty claims can only be made if commissioning work is carried out correctly and written evidence thereof is provided.

It is recommended to fill out the commissioning report chapter 15.

Safety information

◆ Commissioning may only be carried out by adequately qualified persons, details see Table 1 *Qualifications*, page 2.

Preconditions

- ◆ Installation and electrical connection have been correctly performed.
- ◆ Residual material from installation and foreign objects have been removed from the fan and ducts.
- ◆ Inlet and outlet are free.
- ◆ Safety devices have been fitted.
- ◆ Ground cable is connected.
- ◆ Cable glands are tight.
- ◆ Data on the name plate corresponds with the connection data.

9.1 Tests

◆ Before switching the fan on, check for externally visible damage and ensure that the protective equipment functions properly.

1. Switch the fan on.

2. Do the tests requested in the commissioning report (15 *Commissioning Report*, page 27)

Speed controllable fans: "Measured data at commissioning" at maximum speed

3. Switch the fan off.

9.2 Commissioning of speed-controlled fans

Check the fan for vibrations at all normal operation speeds during commissioning. Determine and evaluate vibrations on the housing and bearing areas in accordance with DIN ISO 14694 depending on motor power and positioning.

Measurable vibration velocities depend e.g. on following factors:

- positioning
- bottom section/foundation state
- flow conditions

The working point of the fan, as well as used external devices and accessories, also influence the running characteristics.

9.3 Adjusting the blade angle

If the working point of the fan has to be changed and it is necessary to adjust the blade angle, please contact Systemair!

10 Operation

Safety information

Warning: Hazard from electrical voltage or moving components.

◆ Operation may only be carried out by adequately qualified persons, details see Table 1 *Qualifications*, page 2.

Preconditions

- ◆ Ensure access only to persons who can safely handle the device.
- ◆ Only use the fan in accordance with the operating instructions and the operating instructions for the motor.

Speed-controlled fan operation

Please observe 8.3 *Frequency converter (if used)*, page 21.

11 Troubleshooting/maintenance/repair

Safety information

- ◆ Troubleshooting/maintenance/repair may only be carried out by adequately qualified persons, details see Table 1 *Qualifications*, page 2.
- ◆ Observe the 5 rules of electrical safety, see 2.3 *5 rules of electrical safety*, page 2.
- ◆ The impeller must be at a standstill.

11.1 Troubleshooting

Table 11 Troubleshooting

Problem	Possible causes	Corrective actions
Fan does not run smoothly	Impeller imbalance	Rebalancing by a specialist company if possible, otherwise contact Systemair.
	Soiling on the impeller	Clean carefully, rebalance
	Material decomposition on the impeller due to aggressive material conveyed.	Contact Systemair
	Impeller rotates in wrong direction.	Change direction of rotation (swap two phases in case of a 3-phase motor)
	Deformation of impeller due to excessive temperature.	Ensure that the temperature does not exceed the certified value/Install new impeller.
	Fan operation in resonant frequency range	Consider chapter 8.3 <i>Frequency converter (if used)</i> , page 21
Air output of fan too low	Impeller rotates in wrong direction.	Change direction of rotation (swap two phases in case of a 3-phase motor)
	Wrong wiring configuration (e.g. Y instead of Delta).	Check and possibly correct the wiring configuration.
	Intake or pressure paths are blocked	Remove the blockage
Thermal contacts/resistors have triggered	Motor overheated	Check the cooling impeller (if used), measure the motor winding (if possible) / contact Systemair
	Impeller rotates in wrong direction.	Change direction of rotation (swap two phases in case of a 3-phase motor)
	Missing phase	Check if all 3 phase are present
	Motor blocked	Contact Systemair
Fan does not reach nominal speed	Control units (if used) such as frequency converter or transformer are set incorrectly.	Correct the settings of the control units.
	Defective motor winding	Contact Systemair
	Improperly aligned drive motor	Contact Systemair
Motor does not rotate	Mechanical blockage	Remove the blockage
	Incorrect supply voltage	Check the supply voltage, re-establish the voltage supply.
	Faulty connection	Disconnect from the power supply, correct the connection, see circuit diagram.
	Temperature monitor has responded.	Allow the motor to cool down, find and resolve the cause of the fault.
Electronics/motor overheated	Insufficient cooling	Improve cooling.
	Ambient temperature too high	Check if the correct fan is used for your application.

**Note:**

For all other damage/defects, please contact Systemair. Defective safety-relevant fans (for Ex and smoke extraction applications) must be replaced completely.

11.2 Maintenance

Warranty claims can only be made if maintenance work is carried out correctly and written evidence thereof is provided.

We recommend regular maintenance intervals to ensure continuous fan operation. These maintenance intervals are specified in the "Activities" table below. In addition, the operator must carry out follow-up activities such as cleaning, replacing defective components or other corrective measures. For traceability reasons, a maintenance plan must be created which documents the work carried out. This must be created by the operator. If the operating conditions are "extreme", the maintenance intervals must be reduced so that maintenance is carried out more frequently. Examples of extreme operating conditions:

- Fan unit in rare use (less than once a month)
- Fan used for emergency operation
- Durable ambient temperature > 40 °C or < -10 °C, or temperature fluctuations > 20 K

The following check list provides points of reference for the tasks to be carried out.

Table 12 Activities

Activity	Normal operating conditions		Extreme operating conditions	
	Every six months	Annually	Quarterly	Every six months
Check the fan and its components for visible damage, corrosion and contamination.		X		X
Check the impeller for damage and imbalance.		X		X
Clean the fan/ventilation system (see 12 <i>Cleaning</i> , page 26).	X		X	
Check the screwed connections for damages/defects and check that they are firmly seated.		X	See normal operating conditions	
Check the fan intake is free from contamination.		X		X
Check that the fan and its components are being used correctly.	X		See normal operating conditions	
Check the current consumption and compare this with the rated data.		X		X
Check the vibration dampers (if used) are working correctly and check for visible damage and corrosion.		X	See normal operating conditions	
Check the electrical and mechanical protective equipment is working correctly.		X	See normal operating conditions	
Check the fan's rating plate is legible.		X		X
Check the connection clamps and screwed cable connections for damage/defects, and check that they are firmly seated.		X	See normal operating conditions	
Check the flexible connectors for damage.	X		See normal operating conditions	
Check the function of the standstill heating (if used)		X	See normal operating conditions	
Check the lubrication device (if available). See the manual of the motor.		X		X

Table 13 Activities for fans used for emergency operation.

Check (if present)	Activity	Every six months
Operational readiness of the fan unit	Allow the fan to run for 1 hour	X

Activities for fans used for emergency operation. cont'd

Operational readiness of the emergency system	Allow the "emergency" system to run for 15 minutes	X
Function of the "emergency" control	Test whether the "emergency" control effectively bridges all the other controls and switches	X
Function of the standstill heating	Switch the motor off. The standstill heating must switch on automatically and remain switched on	X

11.3 Variable-speed fans

Important

The fan may be destroyed due to unpermitted frequencies.

- ◆ Pay particular attention to damage from vibrations.
- ◆ After commissioning, start with shorter maintenance intervals.
- ◆ If no damage occurs, adjust the maintenance intervals up to the those stated in the operating instructions.
- ◆ Responsibility for gradual adaptation is with the system operator.

11.4 Overhaul/further maintenance

Pay attention to the safety references and preconditions as in normal maintenance. For the following activities and functions, contact Systemair:

- complete overhaul of motors
- replacement of bearings
- re-winding of motors
- monitoring of condition
- vibration analysis

Extension of maintenance intervals

- ◆ Systemair axial fans without VDD need to be maintained after a 20,000/40,000 hours of operation (depending on the type of motor bearing) or at the latest after 5 years.
- ◆ The maintenance intervals can be prolonged using VDD, as shown in the table below.

	after hours of operation:		at the latest after:	
	without VDD	with VDD	without VDD	with VDD
motor with closed bearings	40000 hours	60000 hours	5 years	8 years
motor with open bearings	20000 hours	40000 hours	5 years	8 years

If the fan is operating with VDD, maintenance action is necessary after above specified time or if the limit values for vibration according to ISO 14694:2003 are exceeded.

Steps to maintain a Systemair axial fan:

- ◆ Check the condition of the shaft sealing rings and shaft bearings and take action if necessary.
- ◆ If the motor is equipped with a relubrication device, relubricate according to the specifications of the motor manufacturer.

Work before switching on again

- ◆ Attach all the safety and protective devices tightly and securely.
- ◆ Remove all the devices with which you have blocked the rotor.
- ◆ Remove all assembly residues and foreign bodies from the area around the fan unit.

11.5 Spare parts

- ◆ Use original spare parts from Systemair only.
- ◆ When ordering spare parts, please specify the serial number of the fan. This can be found on the name plate.

12 Cleaning

Safety information

- ◆ Cleaning may only be carried out by adequately qualified persons, details see Table 1 *Qualifications*, page 2.
- ◆ Observe the 5 rules of electrical safety, see 2.3 *5 rules of electrical safety*, page 2!

Preconditions

- ◆ The power supply has been switched off (all-pole circuit breaker).
- ◆ The impeller must be at a standstill.

13 Deinstallation/dismantling

Deinstall and dismantle the fan in reverse order of installation (7 *Installation*, page 13) and electrical connection (8 *Electrical connection*, page 19).

14 Disposal

- ◆ Ensure material is recycled. Observe national regulations.
- ◆ The device and the transport packaging are predominantly made from recyclable raw materials.
- ◆ Disassemble the fan into its components.
- ◆ Separate the parts according to:
 - reusable material
 - material groups to be disposed of (metal, plastics, electrical parts, etc.)

15 Commissioning Report

Warranty claims can only be made if commissioning work is carried out correctly and written evidence thereof is provided.

Fan

Description: _____
 Article no.: _____ Manufacturing order no.: _____

Installer

Company: _____ Contact person: _____
 Company address: _____
 Tel. no.: _____ Email: _____

Operator (Place of installation)

Company: _____ Contact person: _____
 Company address: _____
 Tel. no.: _____ Email: _____

Type of connection	Yes	No
Directly to mains	<input type="checkbox"/>	<input type="checkbox"/>
0-10 V signal (EC motor)	<input type="checkbox"/>	<input type="checkbox"/>
via contactor control	<input type="checkbox"/>	<input type="checkbox"/>
Transformer	<input type="checkbox"/>	<input type="checkbox"/>
Frequency converter	<input type="checkbox"/>	<input type="checkbox"/>
	Sinus filter	<input type="checkbox"/>
	Shielded cables	<input type="checkbox"/>

Motor protection	Yes	No
Motor protection switch or motor protection relay	<input type="checkbox"/>	<input type="checkbox"/>
PTC resistor	<input type="checkbox"/>	<input type="checkbox"/>
	Resistance value [Ω]: _____	
Thermal contact	<input type="checkbox"/>	<input type="checkbox"/>
Electrical motor protection	<input type="checkbox"/>	<input type="checkbox"/>
Others: _____		

Functional check	Yes	No
Impeller easily rotatable (by hand)	<input type="checkbox"/>	<input type="checkbox"/>
Rotation direction acc. to directional arrow	<input type="checkbox"/>	<input type="checkbox"/>

Nominal data - Fan (name plate on fan housing)

Voltage [V]: _____ Current [A]: _____
 Frequency [Hz]: _____ Power [kW]: _____
 Fan impeller speed [rpm]: _____

Measured data at commissioning

Voltage [V]:	Temp. of transported air [°C]:
Current L1 [A]*:	Fan impeller speed [rpm]:
Current L2 [A]:	<i>"Air volume", "Differential pressure" not necessary for Jet fans</i>
Current L3 [A]:	Air volume [m ³ /s]:
<small>*For single-phase fans, fill in line "Current L1 [A]"</small>	Differential pressure [Pa]*:
	<small>*Δ- Pressure between suction-side and discharge of the fan</small>

If an air flow measurement is not possible, this value can be calculated using the following formula:

$$\frac{\text{Duct cross-section [m}^2\text{]}}{\text{Flow speed [m/s]}} \times \text{Grille measurement acc. to VDI 2044} = \text{Air volume [m}^3\text{/s]:}$$

	Yes	No
Commissioning of the fan successful?	<input type="checkbox"/>	<input type="checkbox"/>

Date, installer's signature

Date, operator's signature



Systemair GmbH
Seehöfer Str. 45
97944 Boxberg
Germany

Tel.: +49 (0)7930/9272-0
Fax: +49 (0)7930/9273-92

info@systemair.de
www.systemair.de